

Spring 2024

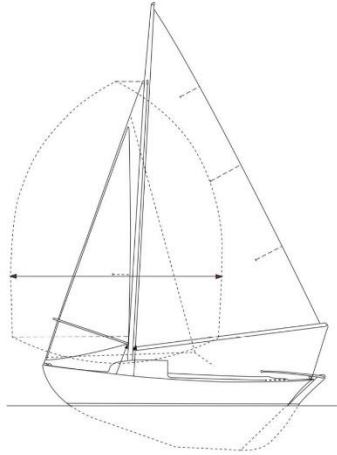

---

## BULLSEYE SAILING ASSOCIATION

---

[Bullseye Sailing Webpage](#)



### President's Message

Welcome all Bullseye Sailors to the Spring edition of the Bullseye Sailing Association newsletter. I hope you all had a great 2023 sailing season!

As an Association, we gave out two one-thousand-dollar grants to Marion Yacht club and to the MDI sailing club to make repairs to their club boats. If your club has a need for something that will benefit all the members fill out the form that is online and send it to the board and we will vote on the request.

This year we were able, with the assistance of Team One Newport, to set up a clothing store for Bullseye apparel. Please check out the site and order lots of gear. Be the first to wear

Bullseye Logo clothing at your club. Here is the link, and you can also find it on our website: <https://www.team1newport.com/Bullseye-Sailing-Association/departments/1526/>.

The Card Sound Sailing Club has asked the Association members to make a change to the use of the jib club. The request will be part of this newsletter and we will be voting on it at the annual meeting. Another request that the board is asking for at the annual meeting in April is that we move the Annual meeting to a day and time during the Annual Regatta and that the new board will take over after the meeting. Currently the new board takes over on July 1 following the annual meeting. We thought that we would have a better turnout at the annual meeting; we can still set up a zoom for those that cannot attend. The Annual Meeting this year will be on April 28 at 4pm by Zoom. We will send out an agenda and Zoom link a few days before the meeting. We would like to see a lot of new faces this year!! If you would like to be on the board, or be an

Spring 2024

officer, please reach out to Joan Tiffany, head of the nominating committee. I would like to finish this message with a great big thank you to our Secretary, Laura Hallowell, who keeps me informed of when I need to get the meeting set up and, she does a great job with the minutes. Laura is going to retire from the Secretary position this year. Another big thank you to David Burnham, our Treasurer, who is also going off the board to spend more time with his family; David also sets up our Zoom meeting!! Lastly, thank you to Kyle Stearns, our newsletter editor, who has allowed us to “spread the word”; he has submitted his resignation for personal reasons and will follow through to assist whomever is nominated to fill the role. Don’t forget to circle the dates on your calendar, July 25-28<sup>th</sup>, for this summer’s National Regatta in Winter Harbor! I Hope to see a big crowd here.

Peter Drinkwater

President

## Waypoints

News, Events, Articles

### Membership Dues Reminder

Dear Bullseye Sailor,

Many of us have our boats in the water up in New England. If you sail in the summer, it is definitely time to pay your dues - \$30 for an individual and \$50 for a family membership. If you are receiving this notice, we do not have a record of your having paid for this year.

Please let me know if you no longer wish to be an active member of the BSA.

Why pay your dues if your club isn’t hosting the Nationals or you may not be planning to sail in them? The BSA tries to support Bullseye Sailors all over, by supplying technical information and supporting fleet building efforts financially. We have a new grant program to help fleets maintain club boats. Our website helps people sell and find boats, has all the Bullseye Technical Specs and documents, and lots of information on fixing up your boat as well as the archive of old newsletters. We sincerely believe that maintaining our organization will help to keep these great boats sailing for many years.

Please renew your membership for 2024. You can pay your dues on line when you log in on the members page with this email address at <http://www.bullseyesailing.org/> or you can print and mail the attached form, <http://www.bullseyesailing.org/pdf/memberform.pdf>. Consider a family membership if you wish to support Bullseyes more generously. If you have moved on from Bullseyes and do not wish to remain on our list, please contact me at [secretary@bullseyesailing.org](mailto:secretary@bullseyesailing.org).

Please stay safe!

Laura Hallowell

Secretary, BSA

Bullseye Sailing Association Membership Form  
**Individuals and Families**

Dues are **payable to the Bullseye Sailing Association**, and are **due Jan. 1 each year**.  
\$30 for individuals, \$50 for families

Name: \_\_\_\_\_

Additional members (family membership) \_\_\_\_\_

**Please verify your preferred email address. This is very important since most communications are now sent by email.**

Email address \_\_\_\_\_

*If you are renewing, you only need to complete the information below which has changed.*

On the password protected Members page of the website,

I \_\_\_\_\_ do \_\_\_\_\_ do NOT want other members to be able to view my address  
I \_\_\_\_\_ do \_\_\_\_\_ do NOT want other members to be able to view my phone number  
Which number do you want to be viewed?

Address: \_\_\_\_\_ Home Phone \_\_\_\_\_

Cell Phone \_\_\_\_\_

City, State, Zip \_\_\_\_\_

2<sup>nd</sup> address \_\_\_\_\_ 2<sup>nd</sup> address phone \_\_\_\_\_

City, State, Zip \_\_\_\_\_

Boat Name \_\_\_\_\_ Sail Number \_\_\_\_\_

Area Sailed \_\_\_\_\_ Yacht Club \_\_\_\_\_

**Please mail your check and this form to Treasurer David H. Burnham, 238 Jonathan Road, New Canaan, CT 06840.** Dues can also be paid on line.

**I am enclosing (\$30/\$50) \_\_\_\_\_ for (individual/family) \_\_\_\_\_ membership**



## Bullseye Sailing Association

### Grant Request for Club boats, equipment, visiting experts, etc.

Grant Guide lines

1. Intended as a source of funds to help member clubs enhance fleet sailing
2. Max Grant of \$1,000 per application
3. Final granting decision is at the discretion of the executive committee

Examples:

- A. Update a club boat for competitive sailing (new lines, or hardware)
- B. Fleet equipment needs (new marks, automated countdown timer, or other equipment that enhances capabilities)
- C. Fund visiting experts for sail & Learn work shops.

Send this form with your request to

Peter Drinkwater wh5n10@myfairpoint 207 460 1458

We will respond asap with an answer to your request for funding.

Email or call me if you have any questions before filling out a request.

## Technical Committee Tools

The technical committee has been busy over the winter with many discussions surrounding our current class rules, regulations, and equipment. One of the items that Phill Nutting worked on was producing a Sail Measurer's Equipment List (below). Please take the time and review the Bullseye Sailing Association Class Rules to ensure compliance.

### Bullseye Sailing Association Sail Measurer's Equipment List

Two 18 - 24 inch long straight edges which can be battens, yard sticks or similar straight hard materials.

Two spikes (ice picks, awls or similar) for pinning the sail to the floor when measuring the sails.

One 25 foot tape measure. Suggest something like a Stanley® FatMax® style wide measuring tape to assist in keeping the measure from twisting.

One pull scale capable of measuring 5 and 10 pounds accurately.

One No. 2 pencil for marking mid points on sails.

One writing pen for recording the measurements taken.

One Measurement log sheet for each suit of sails to be measured.

One black Sharpie® Industrial marker, stock number 13601 which is available at many stationary stores and Amazon.

#### About this product

Handle any work-site marking job with this Sharpie Industrial fine-point black permanent marker. Tackle heavy-duty marking tasks with this Sharpie Industrial fine-point black permanent marker. This marker features a durable, fine-point tip for writing with crisp, clear lines, while the ink withstands temperatures up to 500 degrees, making it ideal for laboratory work. This Sharpie Industrial fine-point black permanent marker writes on glass, film, plastic, wood and stone, and it has resilient, quick-drying ink that resists both water and fading.

- Permanent ink formula is designed to last
- Create clear black lines with this marker, which is well-suited for a variety of office tasks
- Fine-point tip creates thin, accurate lines
- Markers are sold individually

This black permanent marker from Sharpie lets you create fine dark lines on just about anything. Use it in the lab, the garage, the office, or the warehouse to ensure you'll get marks that won't disappear with time.

#### Durable Point

The durable fine point won't bend or get worn down, so every time you write, you'll get the same crisp, clear lines. For larger marks, try a chisel-tip marker instead.

#### Long-Lasting Ink

The long-lasting ink resists chemical washes, so it will remain where you put it for years to come. It also resists UV light, so it won't fade in sunlight or laboratory conditions.

#### Write on Anything

Designed for industrial use, this pen can be used to write on metal, glass, foil, plastic, film, and many other materials. It can withstand extreme heat and steam up to 500 °F.

Measurer qualification or approval.

Over the many years of sailing my Bullseye and going to other fleets for competition I have seen many different levels or interpretations of how sails should be measured. We have gone to great lengths with class rules and technical specs to make it fair. Should the actual measuring be verified it is to the Association's standards?

Should each fleet have an Association recognized and qualified measurer?

Who will be the trainer/qualifier? The Technical Chair?



## Editor's Note

Bullseye Sailing Association membership: Another exciting year approaches as the sailing season commences for the “northern” sailors; looking forward to WHYC hosting the Nationals in picturesque Winter Harbor, ME! While this is perhaps my favorite place to sail, there is also an incredible amount of shoreside activities to explore including but not limited to Schoodic Point, our own eastern part of Acadia National Park, or take the local ferry over to Bar Harbor and visit one of Maine’s greatest island communities with lots of shopping, restaurants, and hiking! Looking forward to seeing everyone Downeast!

With a heavy heart we are remembering the late George Lucas, (obituary to follow), in this newsletter. We lost George back in November, surrounded by his loving family. You may not have known him well, but he was a major force in the organization, president, and involved in every major decision and discussion that we have had in the last 10 years for sure; he truly loved Bullseyes.

On a personal note, after serious consideration, I will be resigning from the Editor role this year. With the “change-of-command” I believe the newsletter responsibility should also be passed-on to maintain appropriate communications for the new leadership. It has been a pleasure serving this community as newsletter editor, and I welcome anyone interested to reach out to the Executive Committee for nomination. I will assist my successor however necessary in fulfilling this role. Thank you for your support and have a safe and successful sailing season!

Best,  
Kyle Stearns



Photo from 2021 Bullseye Nationals Photos, Bullseye Sailing Assn

Spring 2024

IN MEMORY OF

# GEORGE LUCAS

## Obituary for George Lucas

---



8 Bells: George B. Lucas, Jr.

George Brainard Lucas, Jr. died on November 4, 2023, at the age of 89, surrounded by his family and the comforting words of the song, “Bring Him Home.” A loving husband to Patty of 65 years, father to six, grandfather to fourteen, and great-grandfather to four (so far). A gifted wordsmith, poet, lyricist, master woodworker, sailor, skier, golfer, dancer, and piano player. His heart was open to all, and he had a unique ability to make deep, personal friendships with people of all ages.

George was born in Glen Ridge, NJ in 1934 to George and Catherine Lucas. He grew up in Caldwell with older sisters Virginia and Joan, summering in Bay Head sailing Sneakboxes and Lightnings. After graduating Montclair Academy, George attended Lehigh University earning a degree in Industrial Engineering in 1956. His Chi Psi brothers became lifelong friends and he rarely missed the annual Lehigh/Lafayette game. With the mind of an engineer, George had a long and successful career in finance, beginning with his dad at Cooke and Lucas and ending with his son, Russ, at Lucas Capital Management. His career was the perfect fit as George could naturally use his ingenuity, curiosity, and his ability to connect great ideas with others.

His life did not truly begin until, on a summer evening, he met his angel, Patty White. Raised in Berkeley, CA, Patty had the good fortune to visit her aunt in Bay Head during the summer of ‘57. Eight months later they were married and their love story has continued for 65 years. George’s greatest joy was his family: six children, crammed in a station wagon with trips to ski in Vermont and summer down at the shore. A constant teacher, his kids, and grandkids grew up learning to sand and varnish, tie a proper bowline and bowtie, and carve their skis through smooth turns. He often introduced himself by his grandfather's name - “Dust” - because he

would greet everyone covered in sawdust from his woodworking projects. Dust led his family's ski school at Stratton Mountain, yodeling down the mountain with a few dozen descendants tracing his wake, as recently as last Christmas at the age of 88, graceful as ever. George's stewardship encompassed so many parts of his life.

He served on the Board of the Bay Head Yacht Club and as Commodore during the 100th anniversary. He was also the Commodore of the Card Sound Sailing Club, member of the New York Yacht Club, Anglers Club, Card Sound Golf Club, and Manasquan River Golf Club. He was especially proud of his time on the board of the Herreshoff Maritime Museum. His love of boats was infectious, sailing and racing on his Barnegat Bay and he also loved cruising the waters of Maine, Buzzards Bay, Bermuda, the BVI's and finally landing on Card Sound. Most nights you could find Grandy and Dust sitting on the deck watching the sunset over Quest, Harbinger, and Jigger.

Dust's spirit lives on in Patty, the love of his life, his sister Joan Brandley, their children Pam Rew, Russ Lucas, Nancy Mignon, Betsy Vreeland, Margaret Sellig, and Joe Lucas, and son-in-laws, Dan, Joe, Garret, Ralf, and Dave and grands, Molly, Margaret and Owen, Grace and Matt, Patrick and Brooke, Jane and Mike, Luke Maddie and Harry, Annie, Julia and Peter, Meg, Elizabeth, Addie, George, and Fritz. As well as his great grands, Kailie, Zephyr, Brooks, and Capen. We love you, Dust! A Celebration of Life will be held on Saturday, November 11, 2023, at Sacred Heart Church in Bay Head at 10 am. In lieu of flowers, please consider a donation to Save Barnegat Bay. [www.savebarnegatbay.org](http://www.savebarnegatbay.org) [CLICK HERE](#)

This obituary is protected by copyright by O'Brien Funeral Home - Brick. Proudly Serving the Communities of Brick, Point Pleasant, Brielle, Howell, Lakewood, Bay Head, Lavalette, Point Pleasant Beach, Jackson, and Mantoloking . O'Brien Funeral Home - Brick is located in the state of New Jersey, United States.



"701, GEORGE LUCAS" Photo from Chip Riegel 2014 Bullseye Nationals, Fishers Island



## Yacht Club Reports

*Please share your sailing season events and achievements with the membership!*



### Card Sound Sailing Club

March 18, 2024

Bullseye Association, Technical Committee

Peter / Niko / Chris

I am writing on behalf of the Card Sound Sailing Club requesting a change in the Bullseye Class Specifications to permit the individual Clubs to determine whether to allow direct sheeting. At this point neither Winter Harbor nor the CSSC mandate use of the jib club.

We have provided the jib track measurements, pictures and results of testing with/without the Club in past communications. Generally, at CSSC the jib tracks measure 13-16 inches in length, the forward screw being 56 inches from the chainplate and 13 inches off centerline. Admittedly these do vary about an inch in all directions. The car placement on the tracks is, of course, determined by the skipper.

Again, the CSSC is not requesting that the class amend its rules to mandate direct sheeting. We are asking that the individual fleets make the determination. As I understand it. Genoas are permitted at the Nationals when the host club uses them. Spinnakers are utilized in some areas and not at others. Every one design class that I know of develops as it goes along. We should try and make Bullseye sailing inclusive.

Considering all the above, I believe that it is time to put the concept of allowing individual fleets to permit direct sheeting up for a vote by the membership. We propose amending the technical specifications 7.5 jib boom/club to read: Use of the jib club shall be determined by the individual fleets. If it is mandated . . . etc.

Let the membership decide.

Thanks,

Gary Sayia, CSSC Fleet representative

### Sandy Bay Yacht Club, Rockport, MA

Sandy Bay 2023 had a successful year of racing and camaraderie. Membership levels seem to be growing slightly with some senior members stepping away from active sailing often turning their boats over to newer sailors. Our two club boats are race ready and available for members interested in stepping up to a real sailboat. Wednesday night racing saw the most boats on the start line. I believe we had 11 boats on the evening that the junior sailors came out on our two club boats (turns out that dinghy starts don't work well on a bullseye!). We also had a full season of Saturday/ Sunday racing with the addition of Mondays on holiday weekends. 2024 we hope to add a Friday afternoon women's adventure cruise to the schedule to get folks out into the open ocean a bit more. -Chris "Squantch" Sears

### Winter Harbor Yacht Club (2024 Nationals Host)

*I would like to invite you to all to Winter Harbor next summer for the **Bullseye Nationals**. Thursday **July 25th** will be the single-handed races and the **26th and 27th** will be the nationals and Sunday will be a travel day or stick around and watch the Winter Harbor 21s (oldest racing fleet in the US) race on Sunday. -Pete Drinkwater*

### Ask Wendy

*Have a question about your boat? Ask Wendy! Wendy Goodwin, President of Cape Cod Shipbuilding, is happy to answer your questions & enlighten us all.  
Please submit questions to [editor@bullseyeclub.org](mailto:editor@bullseyeclub.org)*

*Feel free to submit any questions you may have to Wendy, or the Newsletter and we will get it out to the membership for assistance! There is a lot of experience within our community, and we are all here to help each other enjoy our boats.*

## Meeting Minutes

### Bullseye Sailing Association

#### Executive Committee meeting 2/25/24

#### 6 P.M. by Zoom

Members present: Peter Drinkwater, Windsor Coffin, Kathryn and Chris Collings, Laura Hallowell, Niko Kotsatos, Gary Sayia, Chris Sears, and Kyle Stearns.

President Drinkwater called the meeting to order at 6 PM.

**Secretary's Report:** Hallowell gave the membership report. In 2023 we had 100 memberships and 131 members. This is about our average in the last few years except for the year when FIYC hosted the Nationals. That year there were 150 members. To date, this year we have an unusually small number of members with 26 memberships and 37 members. This could be because Hallowell sent out the dues notice in November but has not sent out another one recently. She will do so immediately. \*Action

The minutes of the Executive committee meeting of 2/12/23 were approved with one typo corrected.

**President Drinkwater gave Burnham's Treasurer's Report:** The Bullseye Sailing Association (BSA) is in a strong financial position with assets of \$1,000 being held in the PayPal account and \$15,749.10 held in a business banking account through M&T Bank. The total amount of cash on hand is \$16,749.10. This amount reflects a \$742.37 decrease year over year. This is in comparison to \$17,491.57 in 2023, \$15,144.29 in 2022, and \$15,571.33 in 2021. Major disbursements in the 2023-2024 fiscal year included: Advertisement with Bonnier Corp. for digital advertising in Sailing World's One-Design Showcase. US Sailing Membership with placement in the US Sailing One-Design Central, the regatta insurance underwritten by Chubb Insurance and the Gowrie Group and two grants of \$1000 each to the Mount Desert Island Community Sailing organization and Beverly Yacht Club for fleet enhancements. Membership continues to be the primary source of revenue for the BSA. PayPal remains the preferred method of paying dues by a 2-to-1 margin. Each PayPal transaction reduces the net proceeds by 3-4%. However, the convenience of PayPal is worth the small cost, especially if we continue with the Nationals model from 2023 which was transacted as an entirely digital regatta. Burnham also let us know that, with two small children, he will be resigning from the Treasurer's position after the Annual Meeting, but will be available to help the new person transition into the role.

Hallowell said that since she can no longer participate in the Nationals and is spending 6 months in California, she does not feel as in touch with the Association as before. It is time to find a new secretary. Laura is more than happy to work with the new person for as long as it takes them to feel comfortable in the position.

**Old Business:** The Bullseye page of Team One Newport has launched. Go to <https://www.team1newport.com/Bullseye-Sailing-Association/departments/1526/>. Drinkwater has worked hard to get this done. Grant program: The BSA gave two \$1000 grants this year, one

to Beverly Yacht Club and one to the Mt. Dessert Island Community Sailing Program. When Drinkwater said that he was aware of an older Bullseye for a very reasonable price (He should post it on line through Ken Jennings, our boat coordinator \*Action), a fleet building discussion ensued. Kotsatos reported that the BYC fleet is growing. People are noticing the lively competition in the Bullseye fleet and are jumping in from other fleets. The womens' race day is helping. There are two races. The first race is skippered by the boat owner/skipper; this race is scored for the series. The second race is skippered by a woman who was crew in the first race. She does not have to be a BYC member, but often becomes a member after racing.

**Nationals:** Winter Harbor announced a save the date: July 25-27. Three people have already requested loaner boats but they will not be officially awarded until the registration is paid once the NOR comes out. There will be single-handed races on Thursday and the regular regatta races on Friday and Saturday, with awards after the races Saturday. Chris Sears asked if people were in Winter Harbor early, whether the Wednesday 2 pm race would be open to allow visitors to learn the course. Drinkwater will get the answer. \*Action

Launching times for boats will be critical since a ramp is used and a tongue extension is useful on the trailer. The tides are approximately 16 ft.

The rotation is as follows: 2024 WHYC, 2025 BYC, 2026 SBYC, 2027 FIYC, 2028 CSSC?

**Report of the Technical Committee:** There was a full report last year but it has not been distributed to the membership. That should be done. \*Action.

There were questions about how the direct sheeting method was done. Windsor has made a study of the positions of the tracks for the sheets. He reported that they seem to all be in the same general area with some outliers. The question was whether there should be specific language in the official proposal before there is a vote. Remembering the main points of the study, it was found that the sheeting method really did not seem to make a difference in the standings in the races. The jib club makes it very easy to single hand and that is a strength of the Bullseyes. Direct sheeting makes it easier to set up the boat and may be more friendly to people who are coming from other classes of boats.

Kathryn made a study of the regatta rules for other classes. They often say that it is OK for a local club to change an aspect of the technical specs but they need to go back to the one design for regattas. This is the understanding that the BSA has followed and which is in the Class Rules. Direct sheeting would help to train beginning sailors for transitions to other classes. Right now, three fleets are using direct sheeting: CSSC, WHYC and Mt. Dessert Island Community Sailing. It was noted that a very long time ago, one design standards only referred to the hull.

**Note:** Wendy Goodwin objected to this statement when she received the draft of the minutes. She attached a copy of the 1972 Class rules and stated, "From the beginning, our class rules referenced lots more than just the hull. Even then, it was clearly noted that the jib club was mandatory. It's important that the membership not be misled here."

It was decided that the question should be put to the membership at the annual meeting. There appear to be two main questions: Can individual clubs use different sheeting methods? And can those different sheeting methods be used in a regatta? The proposals/questions need to have specifics. The Technical Committee will work with Windsor. Last year's report will be given to our members. \*Action

**Annual Meeting:** There was a proposal to change the date of the annual meeting to be held at the Nationals. Hallowell doubted that there was enough time in the schedule, but others said most other classes do it this way. The motion to approve the change passed 8/1. Windsor checked the Constitution and found that there must be an annual meeting each year. That means we need to hold two meetings this year, and Annual Meeting in April or May and again at the Nationals. It is presumed that our fiscal year coincides with when our officers take office – July 1. A motion to hold our annual meeting for this year on Sunday, April 28 at 4:00 pm by Zoom was approved.

**Fleet Building:** Chris C asked if anyone needed a grant. We would like to use some of our funds to help build fleets. Kathryn had several proposals that could help build fleets:

1. Limiting &quot;pro&quot; sailors from racing in our Nationals? This would apply to level three competitors who are those who have been paid to sail or prepare a boat or crew. Also, there is often a requirement to prove that you are sailing your boat rather than just coming in to win (would need language to allow loaner boats for regular competitors). We approved a motion to create a statement of purpose with specific language. **\*Action**
2. Including a JAM (Jib And Main) &quot;Non-spinnaker &quot; division within the Nationals with a minimum of 5 boats, to be named at a later date. If we were to create this, those sailors would not be eligible for the Goodwin Trophy. However, there would be no requirement for “regular” racers to actually use their spinnaker. The hope is that this would encourage more people to race in the Nationals.
3. Revising the method of receivables and disbursements for Nationals to take some pressure off the host clubs. This was done at BYC last summer; it was easy. The procedure would be: register and pay by PayPal; transfer monies to BSA; BSA disperses funds for food and prizes etc. It would require more involvement by the BSA treasurer, but the data is actually provided by the BSA website receipts (?) The concept was tentatively approved subject to comments from Dave H Burnham.
4. Thoughts of changing the Card Sound Filial Trophy to the George Lucas or the Lucas trophy? This would be up to CSSC. Last year’s Executive Committee asked Phil Nutting to reorganize the sail measuring Tech Specs without changing any content. Phil is working on that now. **\*Action**

Drinkwater reported that he is hopeful that Joan Tiffany will chair the Nominating Committee. She is thinking about it.

The meeting was adjourned at 8:10 pm.

Respectfully submitted,

Laura Hallowell, Secretary



**Classifieds**

*Please refer to website for most up-to-date listings*

**NEW! For Sale - \$8,500** Owner: John Sinnott, PO Box 1464, Mattapoisett, MA 02739 Phone: 774-260-0436, email: [johnsinnott80@gmail.com](mailto:johnsinnott80@gmail.com) Boat Location: Cranberry Island Boat Yard Cranberry Island, ME Sail # 423, Boat Name: Delmar, Hull number 5262, Date of Mfg. 1961+/-, Colors: Topsides: Dark Red, Boot Top: Gray, Hull: White Gray, Deck: Gray. Sails: Main Harding Fair Condition, Jib and Spinnaker Harding Good condition. Gear: Spinnaker pole, Compass, Winches, Jib Clutch, Anchor, Boom Rest, Lifting Sling, bilge pump, Remarks: Boat always stored indoors winters. Brightwork refurbished 2020. Photos available by request.

**For Sale - \$8,500** Owner: Peter Scott, Wakefield, MA 01880 Phone: 781-640-9710, [pscott@scottandscott.us](mailto:pscott@scottandscott.us) Sail # 330, Boat Name: LX, Hull number MSZMT116K202, Date of Mfg. 1961, Colors: Hull: Silver Grey, Deck: Cobalt Blue. Sails: Main and Jib: Quantum Excellent Condition, Gear: Winches, Vang, Jib Clutch, Anchor, Boom Rest Trailer: 2005 Loadrite Good Condition. Remarks: New Rudder, new shroads, Boat stored inside since 2011.

**For Sale - \$8,500** Owner: Joe Bourneut, Ipswich, MA 01938 Phone: 978-312-6270, email: [bourneut@gmail.com](mailto:bourneut@gmail.com) Sail # 262, Boat Name: Curlew, Hull number MSZ00296F222, Date of Mfg. 1962, Colors: Topsides: White, Boot top: Red, Hull: Blue, Deck: Light Blue. Sails: Main and Jib 2020 Quantum Excellent Condition, Genny and Spinnaker Thurston Good condition. Gear: Spinnaker pole, Genoa Tracks, Boom Vang, Jib Clutch, Anchor, Boom Rest, Cockpit Cover. Lifting Sling, bilge pump, Trailer: 2010 Triad w/ extension tongue. Remarks: Boat entirely restored in 2014, Brightwork refurbished 2022. Stored indoors 2014-2022. Shrinkwrapped 2022-23. Photos available by request.

**For Sale - \$6,500** Owner: Molly Keels, Sarasota FL, 34242 Phone: 941-346-1339, cell: 941-356-1559 preferred, E-mail: [mmkeels@verizon.net](mailto:mmkeels@verizon.net) Boat location: Sarasota Sail # 508, Boat name: Conch Pearl, Hull number 3, date of mfg. 1965 Boat colors: deck white, topside white, boot top red, hull white Sails: Main by Thurston in good condition, genoa by Thurston in good condition Gear: Spinnaker pole, boom vang, jib clutch, anchor, boom rest, cockpit cover in fair condition, lifting sling, pump. Remarks: This Bullseye has been in the family for a long time- re-gel coated in 2014 new varnishing, and bottom paint 2018.

**For Sale - \$14,000** Owner: Theodore and Suzanne Murphy, North Smithfield, RI 02896 Phone: Cell 401-636-0203, 401-651-1957, e-mail: [murphyted@cox.net](mailto:murphyted@cox.net) or [murphysuz@cox.net](mailto:murphysuz@cox.net) Boat location: Winter Harbor, Maine Sail # 901, Boat name: Bound for Glory, Hull number 10-2001 colors: Deck gray, topside navy, boot top white hull red. Sails: (2 sets of sails) First set; 1 main sail by Thurston in excellent condition, 1 working jib by Thurston in excellent condition, spinnaker in excellent condition second set: 1 main by Doyle in good condition, 1 working jib by Doyle

## Spring 2024

in good condition. Gear: spinnaker pole, boom vang compass, winches, jib clutch, anchor, boom rest, cockpit cover in good condition, pump. Trailer: Triad, year 2001, in good condition. Remarks: Maintained annually, stored inside, two owners.

**For Sale - \$21,500** Owner: John Lund, Beverly, MA 01915 Phone: 978-810-8380, e-mail: [johnwlund66@gmail.com](mailto:johnwlund66@gmail.com) Boat location: Home, Beverly, MA Sail # 889, Boat name Rose, Hull number CAC00702C000, Date of Mfg. 2000 Colors: Topside: white, Boot top: white, Hull: green. Sails: Main by Quantum in good condition, Genoa by Quantum in excellent condition, Working Jib by Quantum in good condition. Gear: Genoa Tracks, compass, winches, anchor, boom rest, cockpit cover in good condition, lifting sling, outboard bracket, pump, fiberglass seats, oiled hiking stick, ladder. Outboard Motor: Honda, 2 HP, year 2002 in excellent condition. Trailer: Make: Triad year 2002, extra wheel for trailer. Remarks: One owner, stored indoors.

**For Sale - \$10,500** Owner: Andrew & Douglas Doben, Swampscott, MA 01907 Phone: 978-578-0062, e-mail: [dougdoben@comcast.net](mailto:dougdoben@comcast.net) Boat Location: Marblehead, MA 01907 Sail # 138, Boat Name: Innisfree, Hull Number: 17, Date of Mfg.: 1957 Colors: Deck: grey, Topside: white, Boot Top: red, Hull: blue. Sails: 1 Main sail by Doyle, New in excellent condition, 1 Genoa by Thurston in good condition, 1 Working Jib by Thurston in fair condition (New available on request), 1 Spinnaker in fair condition. Gear: spinnaker pole, Compass, jib club, anchor, boom rest, cockpit cover in excellent condition, outboard bracket, pump. Seats are varnished wood. Trailer: Custom made, reconditioned in 2015. Remarks: Innisfree has been beautifully maintained, original sailed in Boston area, then in Lake Erie, brought back to Marblehead. She is in covered storage and many photos available upon request.

**For Sale - \$16,500** Owner: Jim Sullivan, Cell phone: 973-476-6284, Fax: 973-540-8019, e-mail: [jsullivan@sullivangraberlaw.US](mailto:jsullivan@sullivangraberlaw.US) Boat location: Saunderstown, RI. Sail No.: 34, Boat name: Boomer, Hull number: 34, Date of mfg. 1963. Boat colors: Deck; white, Topside: cream, Hull: ice blue. Sails: Main by Harding in excellent condition, Working jib by Harding in excellent condition. Gear: anchor, boom rest, cockpit cover in good to excellent condition, pump. Trailer: Triad, year 2017, in good to excellent condition. Remarks: Boomer was professionally restored to like new condition in 2017. Boomer has been maintained in pristine condition since then, by same boatyard. Winter storage inside.

## Other Items For Sale

**For Sale ELECTRIC OUTBOARD MOTOR - \$2,000** Owner: Samatha Pullaro, Madison, CT 06443 Phone: 646-734-0384, e-mail: [il\\_risotto@yahoo.com](mailto:il_risotto@yahoo.com) Description: Outboard Motor, 3 HP, Make Torquedo, Model 1003L Long shaft, electric, 1,000 Watt output, Year: 2017, Condition: Excellent. Remarks: Like new and meticulously maintained. All manuals, parts, and accessories included.

Spring 2024

## Used Sails Wanted

Looking for a used Bullseye spinnaker. Contact: Murray Hestley, [hestley@gmail.com](mailto:hestley@gmail.com),  
216-244-1260, Bullseye #429

---

*Corrections or to remove your listing on this web site E-Mail  
the [Bullseye Webmaster](#).*

---

## Replacement Parts

Keep your Bullseye in top shape by using the right replacement parts from the manufacturer. Parts are in stock for new and old Bullseyes.

A complete list of Bullseye replacement parts can be found on the Cape Cod Shipbuilding's [Bullseye Parts](#) page.

## To List Your Bullseye for Sale

To list your Bullseye for sale, download and print the Bullseye For Sale Form PDF and mail it along with a \$25 check made out to the Bullseye Association to:

Ken Jennings, Boat Coordinator

63 Thaxter Road

Portsmouth, NH 03801

Email: [boatcoordinator@bullseyesailing.org](mailto:boatcoordinator@bullseyesailing.org)

## About Us

Fleets located all along the East Coast keep in touch through this newsletter, which is packed with sailing tips, stories, regatta information, and results.

Established fleets and their fleet representatives are below:

Fishers Island, NY

David H. Burnham (FIYC)

Beverly Yacht Club, MA

TBD

Miami and Key Largo, FL

Gary Sayia (CSSC)

Rockport, MA

Chris Sears (SBYC)

Saunderstown, RI

Al Maybach (SYC)

Winter Harbor, ME

Greg Hodges (WHYC)

*Everyone comes together for the National Regatta. The location of the regatta rotates around the fleets. Come join the fun! It only costs \$30 to join. You can find the form on our website, [www.bullseyesailing.org](http://www.bullseyesailing.org)*



Officers

---

President	Peter Drinkwater, <a href="mailto:president@bullseyeclass.org">president@bullseyeclass.org</a>
Vice Presidents	Kathryn Collings, Gary Sayia
Secretary	Laura Hallowell, <a href="mailto:secretary@bullseyeclass.org">secretary@bullseyeclass.org</a>
Treasurer	David H. Burnham, <a href="mailto:treasurer@bullseyeclass.org">treasurer@bullseyeclass.org</a>
Technical Committee Co-Chairs	Chris Collings, Niko Kotsatos, <a href="mailto:techcom@bullseyeclass.org">techcom@bullseyeclass.org</a>
Historian	Jim and Kristen Pluntze, <a href="mailto:kpluntze@yahoo.com">kpluntze@yahoo.com</a>
Boat Builder	Wendy Goodwin, <a href="mailto:wendy@capecodshipbuilding.com">wendy@capecodshipbuilding.com</a>
Nationals Chair for 2024	Peter Drinkwater, <a href="mailto:wh5n10@myfairpoint.net">wh5n10@myfairpoint.net</a>
Nominating Committee Chair	TBD
Newsletter Editor	Kyle Stearns, <a href="mailto:editor@bullseyeclass.org">editor@bullseyeclass.org</a>
Commodore	Windsor Coffin, <a href="mailto:winc226@aol.com">winc226@aol.com</a>
Competition Committee Chair	Kathryn Collings, <a href="mailto:collings.marion@verizon.net">collings.marion@verizon.net</a>

---



HERRESHOFF BULL'S EYE



FISHER'S ISLAND  
SOUND BULL'S EYE

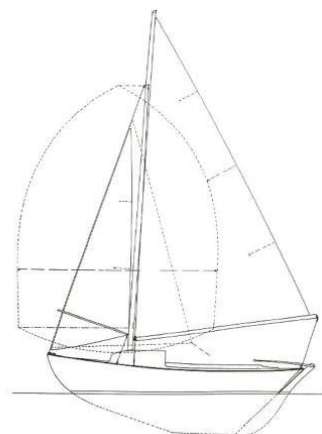

CAPE COD BULL'S EYE

**Bullseye Class Association**



Bullseye Class Association | [secretary@bullseyeclass.org](mailto:secretary@bullseyeclass.org)  
37 High Street, Rockport, MA 01966